

Computer Max

plug & play

Automatic Power Factor regulator



Description

The state-of-the-art **computer Max plug & play** series of regulators has been designed to enable easy, effective regulation. In common with the entire range of computer regulators, it is based on **CIRCUTOR**'s FCP system (Fast Computerized Program), which provides the regulator with unique features in the market Other features include:

- A Plug & Play system that enables fully automatic programming of the C/K parameter and selection of the phase on which the current transformer is installed.
- Views by display: $\cos \varphi$, voltage, current, THD/ and it records maximum voltage and current levels
- Includes the "phase selection" function, which allows the user to select the phase on which the current transformer is installed.
- Allows the user to view the behaviour of $\cos \varphi$, I and THD/ in the event of manual connection and disconnection of capacitors.
- Indication of the following alarms by display or relay: lack of compensation, overcompensation, overvoltage, overcurrent, disconnected transformer, current below limit.

Applications

Computer Max plug & play is the perfect regulator for the compensation of balanced installations, in which ease of programming, robustness and accuracy are essential requirements. Its straightforward, intuitive programming system makes it very easy to install and maintain by the user.

Technical features

Voltage circuit	Power supply voltage	230, 400, 480 Vac (according to the type)
	Tolerance	-10%...+15%
	Consumption	4 VA (max 6) - 6 VA (max 12)
	Frequency	45...65 Hz
Measurement circuit	Measurement voltage	230, 400, 480 Vac (according to the type)
	Measurement current	Transformer I_n / 5 A +20%
Output relay	Maximum voltage	250 Vac
	Nominal current	10 A
	Electrical working life (mechanical)	-25 °C...+55 °C
Alarm relay	Relay	Last relay (if not configured for compensation)
	Alarms	Lack of compensation, overcompensation, overvoltage, overcurrent, disconnected transformer and current below limit
Build features	Operating temperature	-10 °C...+50 °C
	Assembly	Panel
	Dimensions	144 x 144 mm
	Connection	Power strip
	Protection degree	IP 40 (front panel) / IP 30 (rear)
Features	Electrical parameter measurement	$\cos \varphi$, voltage, current, THD/, maximum value of U and I
	"Phase selection" function	Selects the phase on which the current transformer was installed
	Control system	FCP / 4 quadrants
	Connection programs	1.1.1.1 / 1.2.2.2 / 1.2.4.4 / 1.1.2.2 / 1.2.4.8 / 1.1.2.2 / 1.2.2.4 / 1.2.3.3 / 1.2.3.4 / 1.2.3.6 / 1.2.4.6
	Test function	Compensation test and harmonic resonance test
	Connection delay T_r	4...999 s
	Safety delay T_s	5 · T_r
	Standards	IEC 61000-4-2, IEC 61000-4-3, IEC 61000-4-4, IEC 61000-4-5, IEC 61000-4-11

Computer Max

plug & play

Automatic Power Factor regulator

References

Type	Code	Power supply voltage	No. steps
Computer Max 6	R10871	400 Va.c.	6
Computer Max 12	R10872	400 Va.c.	12
Computer Max 6	R10871002	230 Va.c.	6
Computer Max 12	R10872002	230 Va.c.	12
Computer Max 6	R10871004	480 Va.c.	6
Computer Max 12	R10872004	480 Va.c.	12

Dimensions

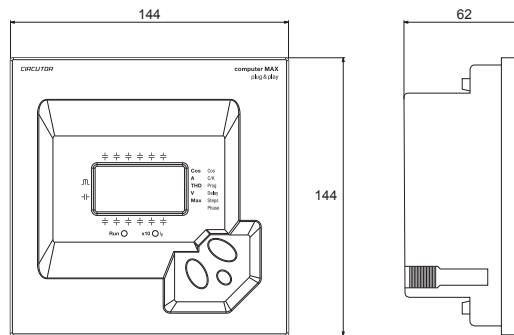

Connections

Computer Max 6

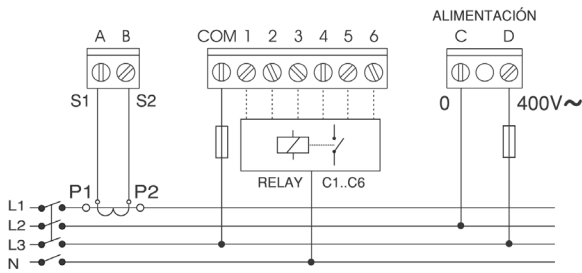

Computer Max 12

