

SERIES 4000

Kilowatt Hour / kW Demand Meter



INSTALLATION AND OPERATION MANUAL

HOW TO RESET MAXIMUM DEAMND (APPLIES TO THE KW4000 SERIES ONLY)

NATIONAL METER INDUSTRIES, INC.

800.325.6674

SERIES KW4000

MODEL KW4240

VOLTAGE 120/208V, 240V 3 PHASE 3 OR 4 WIRE

CT RATING CL 5 TA 2.5 ML 2VA

TURN 



- Insert the key into the Key Switch
- Turn key clockwise to the 2 O'clock position
- Look at the LCD display and notice that "CLEAR" blinks on and off three to four times, then displays Kilowatt Hours.
- Turn the key back to the "Center" position
- Remove the key from the Key Switch

For Techincal Assistance:

P – 800.325.6674

F – 603.668.2700

Email: tech@national-meter.com

INDEX

Short Cut to Resetting the Demand Readings	Inside Front Cover
Introduction	1.
Main Features	2.
The Meter Terminals	3.
Wiring Diagrams	4.
Wiring Instructions	5.
Solid Core Current Transformers	5.
Split Core Model “TP” Current Transformers	6.
Split Core Model “1250” Current Sensors	7.
Operation Mode	7.
Common Terms Used With This Meter	8.
Specifications	9.
Communications	10.
ModBus Protocol	11.
Trouble Shooting	12.
Warranty	Back Cover

INTRODUCTION:

You now have in your possession one of the most reliable and highly accurate meters ever manufactured.

To insure proper installation and performance please take the time to read this manual before installing this meter. The installation information contained within this manual is to be used as a guide and any applicable electrical codes must take precedence over the information contained within.

****WARNING****

We recommend that all electrical circuits that you are working on be DE-ENERGIZED prior to installation of this meter or current transformers. If this is not possible than any and all applicable OSHA Safety Rules, Union Safety Rules or any other applicable safety rules when working with energized circuits must be adhere to. A license electrician must perform this installation for all applicable warrantees to be in effect.

The Series 4000 kit is made up of 4 components; 1 meter and 3 CTs. Solid core CTs up to 400 Amps are included in the standard kit, with larger sizes and split core CTs, up to 10,000 Amps, as an option. The line wires feeding this meter shall be protected with in-line 5 Amp fuses or a 15-Amp 3-pole circuit breaker. Most all of our current transformers have a 5 Amp at F.L. secondary output. **Never leave the black and white wires open when the meter is out of service.** There is an appreciable voltage depending on the rating of the CT and the primary load. An open CT will hum and vibrate in larger sizes.

CHECK FOR SHIPPING DAMAGE and SHORTAGES

The Watt Watcher Meters are shipped in a protective box with the solid core CTs. Large frame Split Core CTs may be in another box. After unpacking your meter please check for obvious damage or missing components. In either case promptly notify the distributor where it was purchased.

ERRORS AND OMISSIONS:

We have taken all precautions to create a complete installation manual. NMI is not liable for any omissions or errors contained within. Please contact us if you have any questions after reading through this manual. Thank You.

NOTE TO THE ELECTRICIAN: PLEASE LEAVE THIS MANUAL WITH THE METER WHEN LEAVING. THANK YOU!

MAIN FEATURES:

The Series 4000 is factory programmed offering one model for both 3 or 4 wire services or branch circuits. The factory has program the Amperage, and a 15-min. demand period (KW4000 only), according to the distributors purchase order.

There are six (6) kWh digits across the top section of the display, which are the kilowatt-hours accumulated. There are no resets available for kWhs, like a utility meter and there are no multipliers needed to read the energy consumed. There are three additional readings along the bottom of the display. These readings are three digits of voltage, three digits of amperage and three digits of instantaneous kilowatts. These power readings will display "HI" when the readings go to 4 digits i.e., 1000 Amps or kW.

The Series 4000 Demand Meter (Model KW4000) will scroll to Maximum Demand (pd). The demand interval is factory set at 15 minutes unless otherwise instructed. Sliding or Rolling Window is the demand method used by this meter.

The factory programs the relay to 1-KWhr per pulse, as a standard unless otherwise instructed. Tighten Relay Terminal screws 5 – 7 inch Lbs.

There is a RS485 ModBus terminal next to the relay. This port works with our Intelligent Converter that plugs into the RS232 Com Port in your computer. NMI offers software programs to Read and Bill or Trend Parameters. Call the factory for more information.

The voltage and the current terminals are removable. If a field calibration check is necessary the terminals simply unplug and a portable meter tester can plug into them. These terminals are a standard feature on all of our meters. Also the CTs have two extra terminals that are used when paralleling two sets of CTs. Remember Current Sensors with voltage outputs cannot be paralleled. Voltage is not additive in parallel, where current is.

There are holes in each corner of the meter for mounting the meter against a plywood board, sheet rock wall or switch boards. We don't recommend that the meters be mounted against a concrete wall. If there are any technical questions that this manual does not cover please call our technical desk at (603) 669.5790.

THE SERIES 4000 CONNECTION TERMINALS

Terminal No.	Designation	Description
L1 – L2	Power Supply	Power Supply at 230 or 480 VAC
Relay	Pulse	Reed Relay
RS 485	ModBus Protocol	RS485 Daisy Chains to other meters
N	N	Neutral
L1	Measuring Voltage	Voltage signal from Phase L1
L2	Measuring Voltage	Voltage signal from Phase L2
L3	Measuring Voltage	Voltage signal from Phase L3
CT1 B&W	Current Transformer	Current or milli-volt signal from CT1
CT2 B&W	Current Transformer	Current or milli-volt signal from CT2
CT3 B&W	Current Transformer	Current or milli-volt signal from CT3

Note:

Color-code and size all wires according to National Electric Code.

Current Transformer wires shall be twisted to cancel noise.

Current Transformer and Line Voltage shall be phase related ie: L1 and CT1 are from the same phase the same with L2 – CT2 and L3 – CT3.

CONNECTION DIAGRAMS FOR THE SERIES 4000

Three Phase 4 wire service, which also includes a Hi-leg Service.

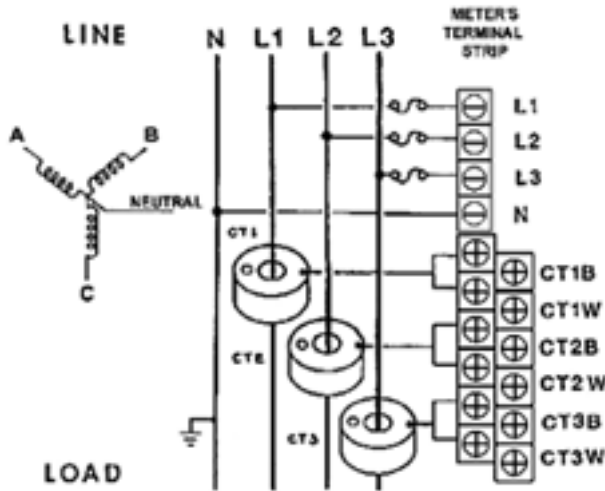

1. Use either 5 Amp in-line fuses or a 15 Amp CB with lock
2. RS485 Terminals (+ GRN -) optional
3. Relay 1 pulse relay

B. Three Phase 3 wire: (either a Delta or 3 wires of a 4 wire Wye service)

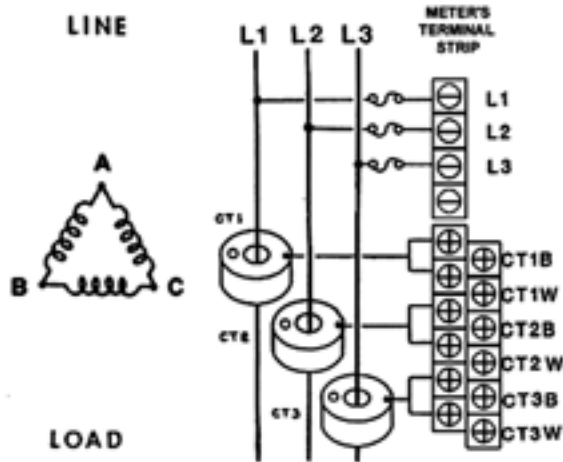

1. 5 Amp in-line fuses or 15 Amp CB with lock
2. RS485 Terminals (+ GRN -) optional
3. Relay 1 pulse relay
- 4.

WIRING INSTRUCTIONS

1. All wiring to this meter must comply with National Electric Code or any local codes that are applicable. A grounding conductor must be installed and connected to the ground lug located under the terminal cover in the meter.
2. The voltage wires connected to the line terminals in the meter can be No. 14 gage. The load for the meter is .03 Amps. Either 5 Amp in-line fuses or a 15 Amp circuit breaker with a locking handle should protect the voltage leads. Tighten each Voltage screw 5 – 7 inch Lbs.
3. The extended wires from the meter to the current transformers can be #16 gauge stranded wire up to 100' and 14 to 200' distance. The voltage and the current wires can be in the same conduit, if you twist the current wires. The CT leads must be shunted if the CT is to be installed before the meter arrives, or if the meter is taken out of service. Never leave the CT leads open on an energized circuit drawing current. Exception is the NMI-1250 split core current sensors. The secondary output of this split core is 110 mv, not current. In this case the black and white wires are capped separately if meter is not connected.
4. Form all wires neatly within the field termination area provided. An extra row of CT terminals are provided if paralleling is required. Both the voltage and the current terminals are removable if field-testing is required in the future. Please check carefully all connections before energizing meter. Tighten each CT screw 10 inch Lbs.

Solid Core Current Transformers

1. Solid Core CTs up to 400 Amps are supplied with this meter. The LX 400 Amp CT works in a range of 4 to 400 Amps. Solid core CTs are as accurate as the split cores but are much smaller. Split Cores are available if the power cannot be turned off. The (H1) or white dot, depending on the manufacture, faces the line side of the service.

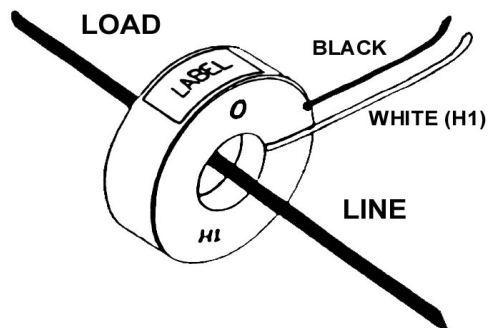

The black wire connects to the CT terminal (B) and the white wire connects to CT terminal (W).

Note: Shunt the black and white wires if the CT is installed and the meter has not been connected. Twist the black and white wires independently from each CT.

Split Core Current Transformers (Model NMI-TP-Series)

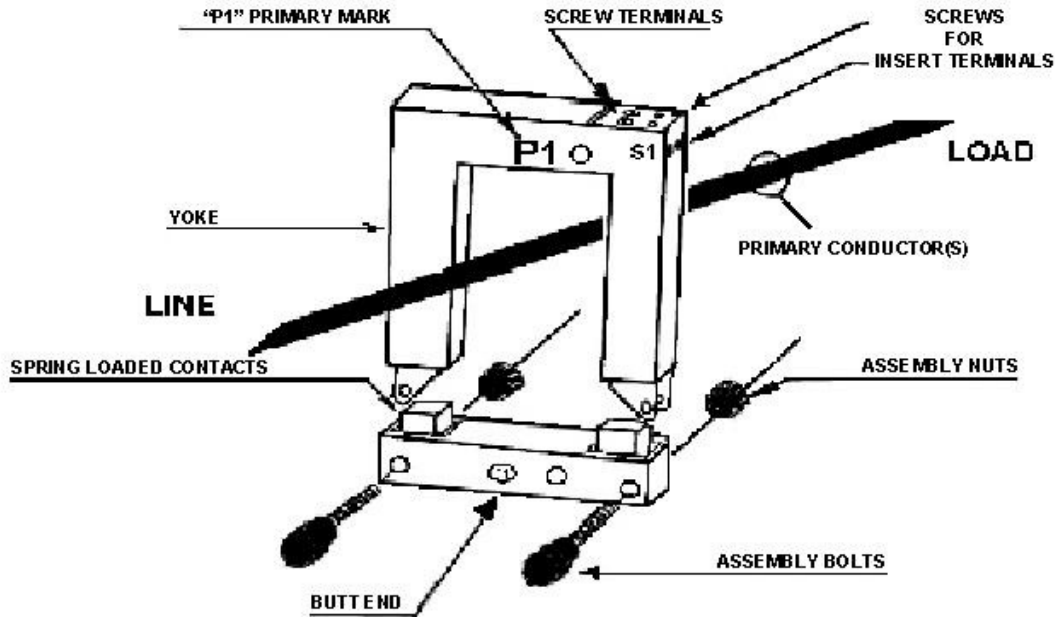

Please refer to the above drawing:

1. Remove and dispose of the packaging materials
2. To remove the end piece, unscrew the assembly nuts, push in on the end piece to relieve the pressure on the bolts. Pull the bolts out and pull the end from the main U shaped housing.
3. Position the “P1” side of the CT towards the line side of the service.
4. There are 2 screw pressure terminals labeled “S1” and “S2”. Connect the white common 5 Amp wire to the “S2” terminal and black wire which is to the “S1” terminal.
5. The other two brass screws can be used for shunting out the CT with the use of a jumper, if needed. Remember to remove the jumper after connecting the CT to the meter. Do not put the CT around an energized conductor unless the CT is shunted or connected to the meter. A open CT will vibrate and hum.

CAUTION: NMI RECOMMENDS THAT YOU TURN OFF ALL POWER BEFORE INSTALLING CTs.

6.

Split Core Current Sensor Model (NMI 1250-400)

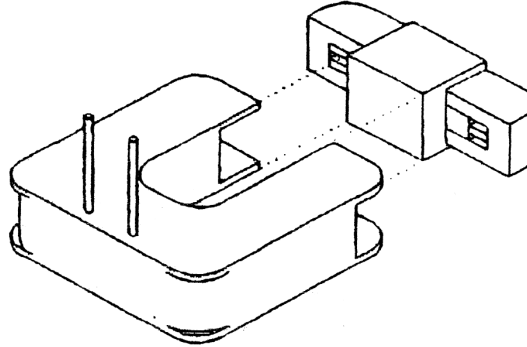

The secondary side of these split core transformers is 110 milli-volts at 400 Amps. You need to cap the black and white wires separately if the meter is not installed at the time the current sensor is working.

Pull hard on the bottom section to open the yoke of the sensor. Install around conductor and snap back together. Twist the black and white wires independently from each sensor. The sensor wires and the voltage wires can be installed in the same conduit. You can run up to 2000' with #16 gage wire.

OPERATION MODE OF THE SERIES 4000

Front Panel of the Series K4000

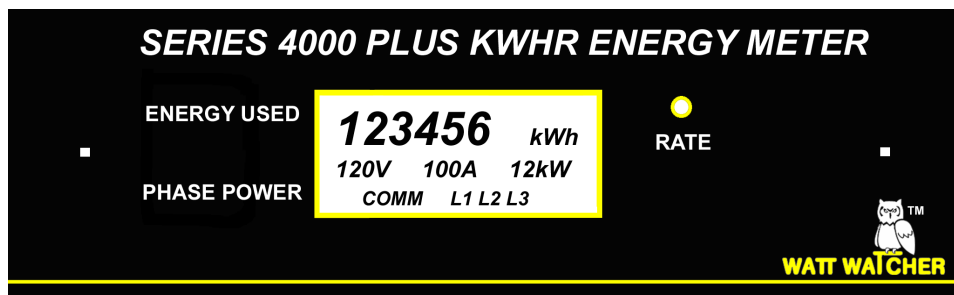

1. The Display has Six kWh 5/16th Digits across the top and three 3/16th digits for Volts, Amps. and (instantaneous) kW No multipliers are needed to read the energy.
2. If Amps and kW are over 999 the display will show "HI"
3. The RATE LED will blink every time one-Kilowatt hour is consumed

7.

COMMON TERM USED WITH METER READINGS

VOLTAGE: The potential between phase and neutral or phase to phase. This can be 120 to 480 volts depending upon the model selected.

AMPERE: A unit of electrical current, which will flow through a resistance of 1 ohm by 1 volt.

WATTS: A unit of active power, which is defined as the rate at which energy is delivered to a circuit. This is the power expended when a current of one Ampere flows through a resistance of one ohm.

kW: A common abbreviation for 1000 watts.

KW DEMAND: A measurement of energy (kW) or (KVA) over a choice of a time interval in 15 or 30 minutes, which is most common. A thumb rule method is to count kWh in 15 minutes and multiply by four. Multiply by two if the demand interval is 30 minutes.

ROLLING OR SLIDING WINDOW: A demand interval that moves in time through a sub-interval. One example would be a 15-minute demand interval could comprise of 15 one-minute sub-intervals. The first 1-minute sub-interval will slide into the next measuring period, dropping the last sub-interval. This is the method used in this meter, and by many utility companies.

WATT-HOUR: A unit of electric energy that measures one watt in one hour. There are one thousand-watt hours in one-kilowatt hour.

HERTZ: A practical unit measuring the number of positive and negative values occurring in one second. Sixty Hz is typical in the US and fifty is used in Europe.

VOLT-AMPERE: A unit of volts and current that flows because of the voltage. Volt-ampere and kilowatts are the same at unity power factor. In an AC circuit with power factor other than unity the VA equal the square root of watts squared plus reactive volt-amperes squared. The greater the VA over kW is reflected by poor power factor.

KVA: A common abbreviation for 1000 volt-amperes.

POWER FACTOR: The ratio of active power (kW) to apparent power (KVA). Power Factor (PF) can be corrected by capacitors or synchronies motors.

THD and D (TOTAL HARMONIC DISTORTION and Distortion):

Lets defined linear and non-linear loads. From a simple and practical point of view, a linear load is that, when supplied by a sinusoidal voltage, absorbs also a sinusoidal current. On the contrary, a non-linear load will absorb a non-sinusoidal current for the same supply voltage, although such current is habitually of periodical type. Representative examples are Static power converters, AC to DC power supplies, Discharge lamp lighting, Arc furnaces, electric welding machines, Transformers, Iron core reactors, etc.

The Distortion can be measured in two different ways, giving parameters known as “d” and “THD”. THD rate is referred to the total R.M.S. value where as d is obtained by multiplying a fundamental voltage by a series of currents with frequencies multiple of the fundamental frequency.

Expected distortion rates commonly found in power systems are 5% and below in voltage and 30% and lower in current. Higher readings do not necessarily mean a faulty facility but should be looked at for a potential problem.

PULSE OUTPUTS: Each pulse represents a predetermined increment of power or other quantities. Relay 1 in this meter is factory programmed for 1 pulse equals 1 kWh.

SPECIFICATIONS:

Power Supply:

Single Phase 230 or 480 VAC in applicable models

Voltage Tolerance -20% to +20%

Frequency 50 to 60 Hz.

Meter Burden 0.5 VA

Operating Temperature 0 to 45 degrees C

Measuring Circuits:

Rated Voltage 300 V. phase to neutral and 500 V. phase to phase

Rated Current 0.5 Amp secondary and (110 mv.) option

Permanent Overload 1.25 %

Current Input Burden 0.75 VA

Accuracy:

Voltage .05 %

Current .05 %

Energy .05 %

Test Temp 0 to 45 degrees C

Power Factor 0.5 to 1

Measured Values between 5% and 100%

ANSI C-12.16 compliant

Mechanical Characteristics:

Enclosure: NEMA 1

Flame Rating: UL 94 VO

Removal Voltage and Current Terminals

Relays:

Maximum Switching Load 8W

Maximum Switching Voltage 200 VAC Peak

Maximum Switching Current 400 mA

Maximum Operations Cadence 3600 operations per hour

Standards:

USL-United States UL Listed

UL 508

CNL- Canadian National Standards CUL

ANSI C12.16 Accuracy Compliant

FCC Class A Part 15

New York City Board of Fire Underwriters

Michigan Compliant

RELAY CONNECTRION TO REMOTE COUNTER

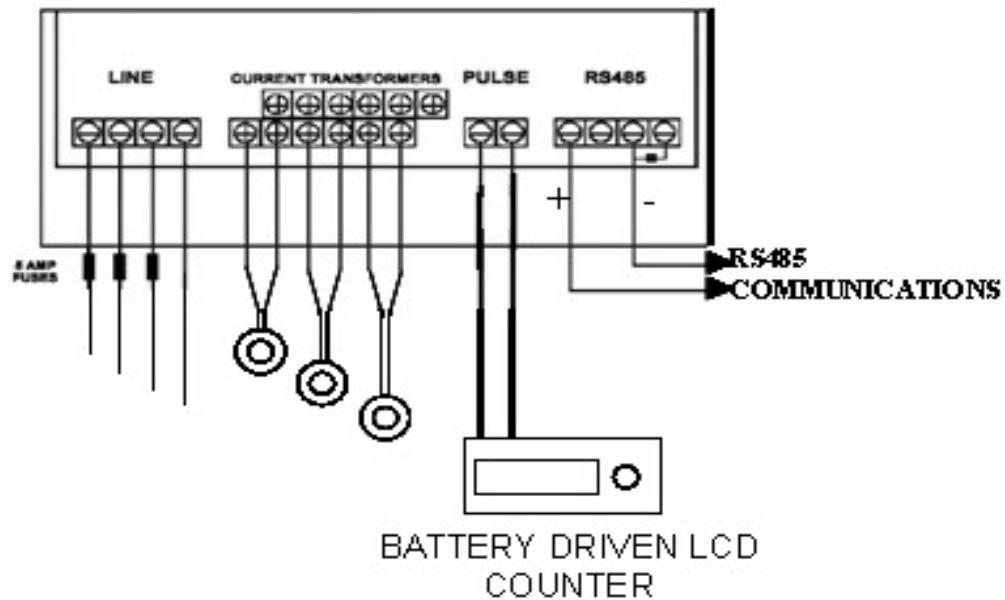

COMMUNICATION NETWORK

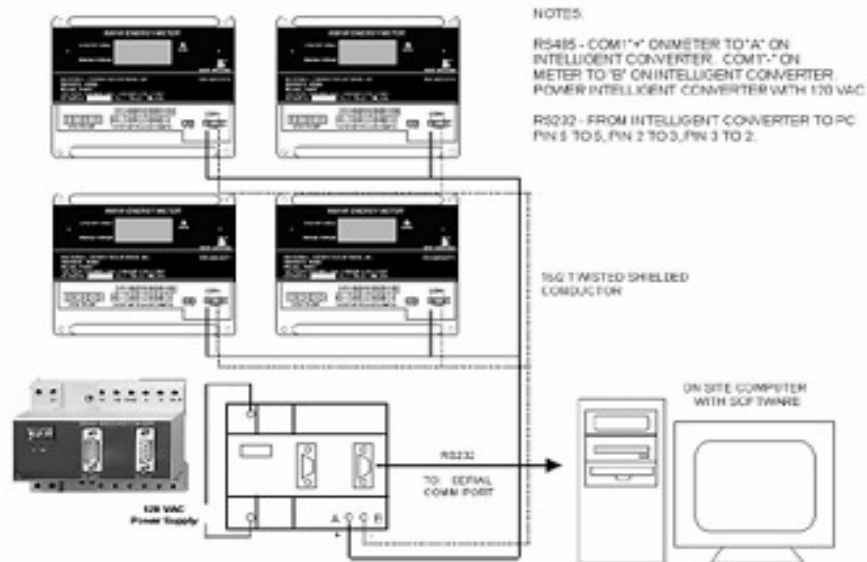

One or more meter can be connected to a PC, so all the parameters can be read at one central location. There is a terminal block marked RS485 (+ GR -) which are the connections for the 2 wire #16 shielded cable. You can connect more than one meter to a circuit, but you must assign a different identification number (Peripheral number) to each meter. This can be expanded by the use of hexadecimal coding and a small Dos App at time of field programming. Tighten Comm. Screws 5-7 inch Lbs.

MODBUS PROTOCOL

The Series 4000 Energy Meter can communicate by means of the ModBus protocol as described below:

When the meter communicates with MoBus, it uses the RTU mode (Remote Terminal Unit). Each 8-bits byte in a message contains two 4-bits hexadecimal characters.

MoBus RTU Protocol, Default Configuration: 001 / 9600 / 8 bits / N / 1 bit
 Baud Rates: 1,200 / 2,400 / 4,800 / 96,000

The format for each byte in RTU mode is:
 Code

8-bits binary, hexadecimal 0-9, A-F
 Two hexadecimal characters
 contained in each 8-bits field of
 the message.

Bits per Byte

8 data bits

Error Check Field

Cyclical Redundancy Check (CRC)

ModBus Functions:

Function 01

Reading of the Relay State

Function 03 or 04

Reading of n words (16 bits-2 bytes)
 This function permits to read all the electrical
 parameters. Each parameters is 32-bits long, hence
 two words are required to inquiry for a parameter. (4
 bytes-xx xx xx xx).

EXAMPLE:

Inquiry

0A	Meter peripherals number, 10 in decimal
04	Reading function
00 00	Initial address (first register)
00 0A	Number of registers to be read
7176	CRC character

Answer

0A 04 14 00 00 08 4D 00 00 23 28 00 00 0F A0 00 00 00
 90 00 00 00 60 2E

0A	Meter number, 10 in decimal
04	Reading function-the one used for the inquiry
14	Bytes received (20)
00 00 08 4D	V X 10 (register 00 Hex), in decimal 212.5 V
00 00 23 28	mA, in decimal 9000 mA
00 00 0F A0	W, in decimal 4000 W
00 00 00 60	PF X 100, in decimal 96 PF
CB 2E	CRC character

Reading digital outputs (relays)-Function 01:

Inquiry PP0100000008CRC (PP = peripheral No.)
 Answer PP0101XXCRC

Where XX (hexadecimal byte)→translated to binary || b7 || b6 || b5 || b4 || b3 || b2 || b1 || b0 ||
 bit b0 = relay 1. (1 = ON; 0 = OFF)
 bit b1.= relay 2. (1 = ON; 0 = OFF)

**NATIONAL METER INDUSTRIES INC.
FIVE YEAR LIMITED WARRANTY**

SUBJECT TO THE EXCLUSIONS LISTED BELOW NATIONAL METER INDUSTRIES INC. (NMII) WILL EITHER REPAIR OR REPLACE ITS PRODUCT WHICH CONTAINS A DEFECT IN MATERIAL OR WORKMANSHIP THE FOLLOWING EXCLUSIONS APPLY:

1. Every precaution has been taken in the preparation of our installation manuals. NMII takes no responsibility for errors or omissions in the installation manuals. NMII is not responsible for any damage or monetary losses, whether direct, indirect, incidental or consequential. All installations shall be made by qualified electricians and all local and national electrical codes shall take precedence.
2. NMII warrants its meters to be free of any and all defects in material and workmanship and will give satisfactory service for a period of (5) five years from the date of purchase. If the meter should malfunction, a call must be made to our customer service department, 1-800-325-6674, within 30 days after the defect becomes apparent, for verification. After verifying a meter malfunction an Authorized Return Number (ARN) will be issued. Sent along with the meter shall be a contact name/phone number and a UPS returnable address. Freight is to be prepaid with the return number written on the packing slip.
3. After examination of the returned meter by NMII technicians proves the meter to be warranted failure, the meter will be repaired or replaced without charge.
4. This limited warranty does not cover the labor costs for removal or reinstallation of the meter and excludes normal wear and tear.
5. This warranty is null and void if the meter shows evidence of having been tampered with, abused, connected to the wrong voltage or if our specifications were exceeded.
6. This warranty does not cover any other product connected to the meter.
7. There are no other warranties, expressed or implied, as to the quality of the product or fitness for a particular application.